

2-speed Swimming Pool Pump with Digital timer

Features

- This high performance, medium head pump comes complete with our unique mechanical shaft seal that allows the pump, if mistreated, to run dry for up to one hour.
- The pump can be used for pool water with a salt concentration of up to 5000 ppm.
- Pump parts are made of 100% recyclable plastic. Non-corrosive, chemical/UV resistant, and can withstand temperatures of up to 175°F.
- All models are equipped with 2" suction and 1.5"/2" discharge unions ensuring optimum efficiency.
- For pool users' safety, the impeller has a dielectric shaft sleeve that provides absolute separation between pool water and electric parts.
- Lock ring that incorporates handles. These handles provide the user with a convenient way to easily remove the lid.
- Large 56 frame pool motor delivers flexibility in motor speed and timer settings.
- Equipped with a built-in timer and an easy to use digital interface.
- Simply program ON/OFF times for Low & High speeds.
- Motor is easy to remove without disturbing the plumbing. Reusable o-rings throughout.
- Two year warranty on the motor and all pump parts, including normal wear of the mechanical seal.
- Every pump is performance tested before leaving the Speck factory.



BADU EcoM2/S90



Trademarks and Certifications



Applications

- Residential pools

Dimensional Drawing

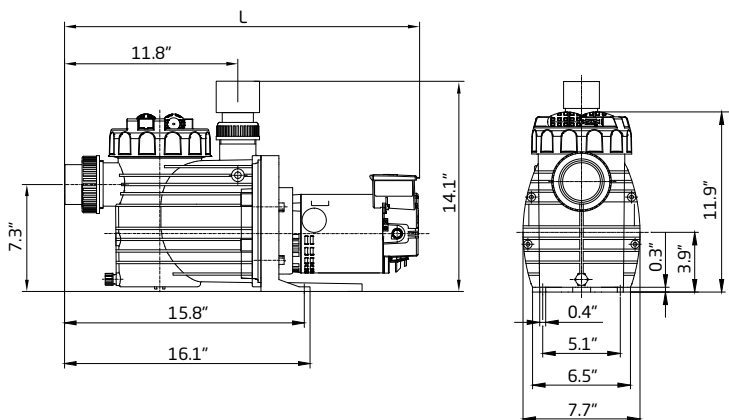

MODEL	DIMENSION "L"	SHIPPING WEIGHT
Badu EcoM2/S90-II	27.25"	44 lbs.
Badu EcoM2/S90-III	27.25"	45 lbs.
Badu EcoM2/S90-IV	27.75"	47 lbs.

Performance Curves

