

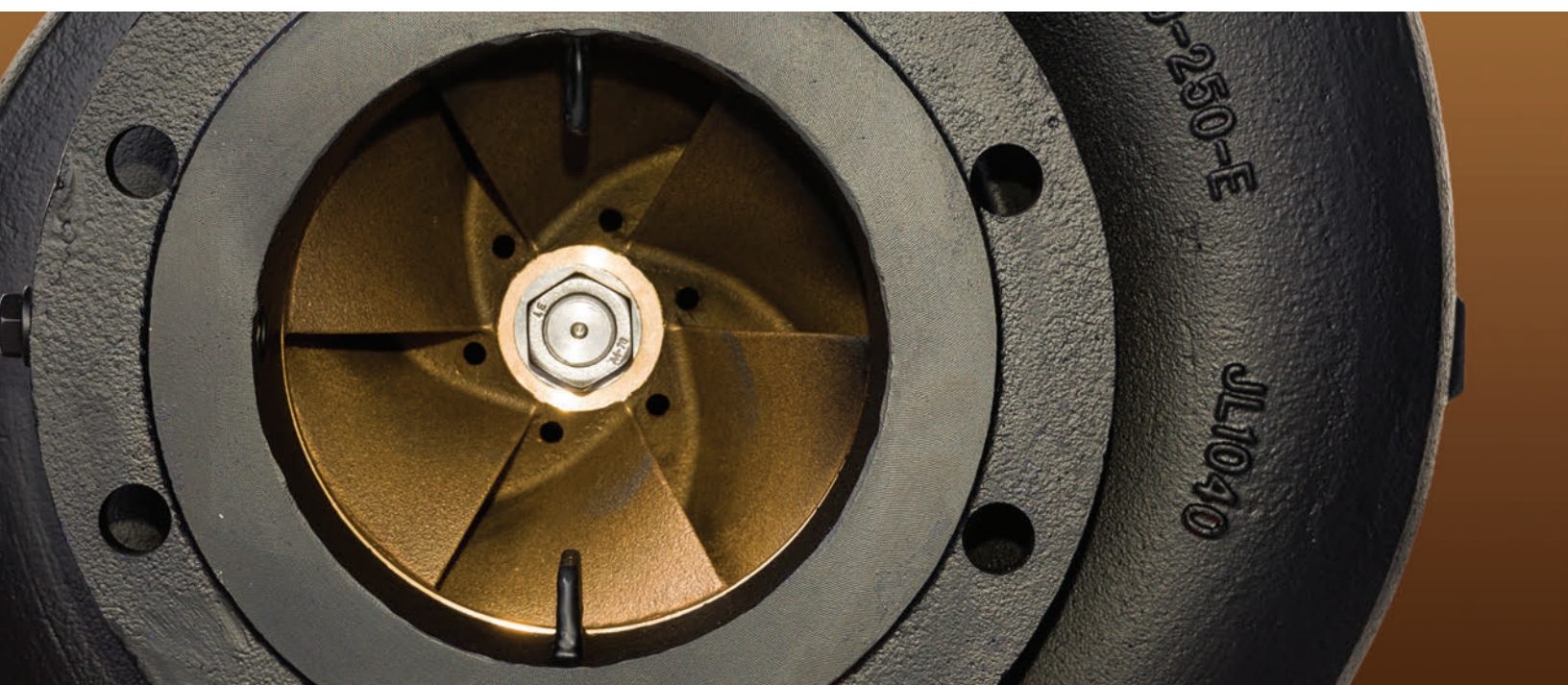

German Engineered. American Manufactured.



BADU[®] Block Series **Normblock Series**

Commercial Pool Pumps

Speck Pumps Multi Series

Durable, Serviceable, Fast.

They say you have to pick two between price, quality, and speed. But what if you didn't?

That's the story of Speck's Block Series. Innovative polyurethane construction keeps prices down while maintaining quality. It's all backed by Speck's industry-best lead times.

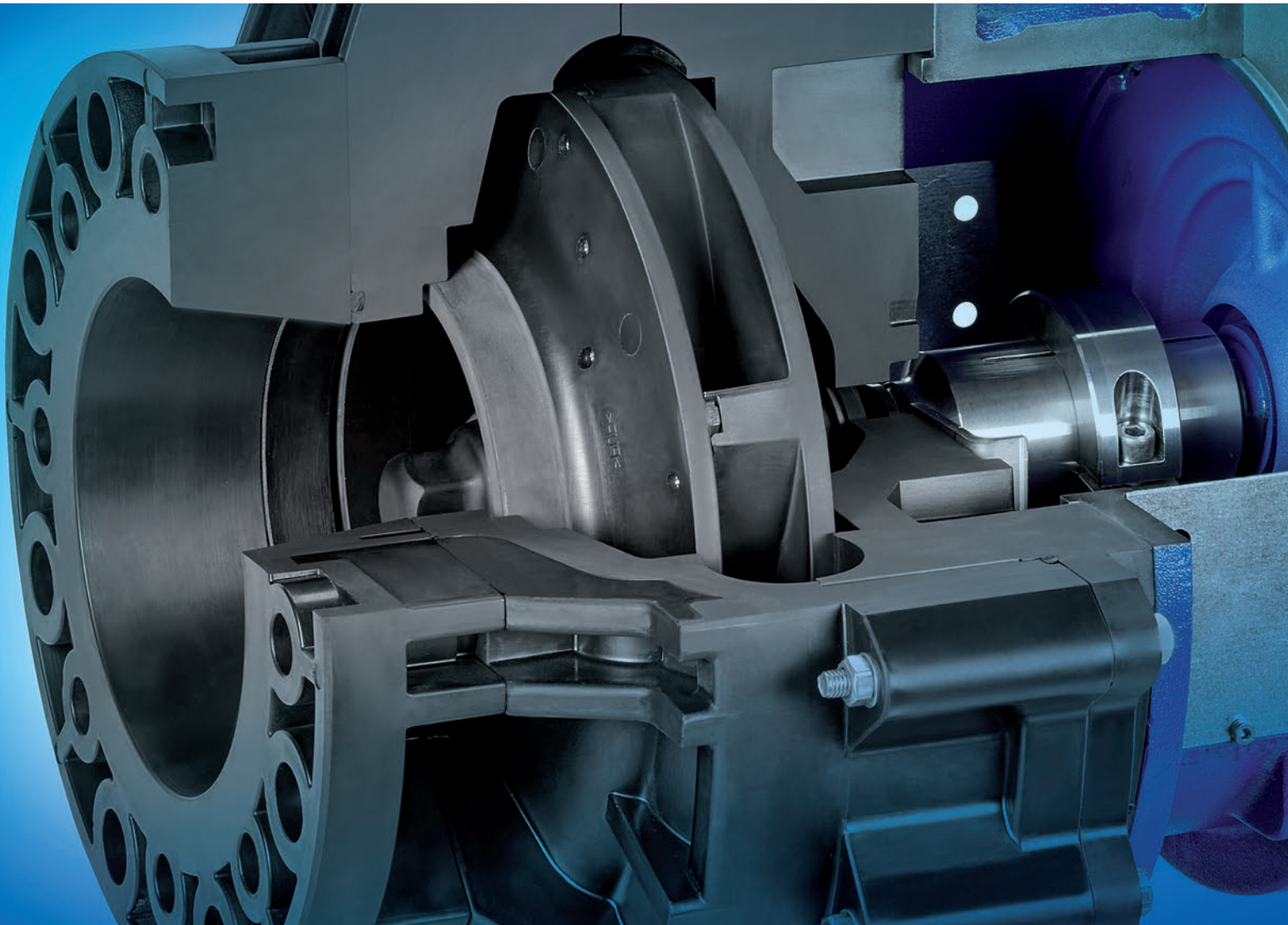

Normblock Multi Series

Our Baseline Horizontal Design



Certified to
NSF/ANSI/CAN 50

FEATURES

- Polyurethane construction at higher horsepower than any other manufacturer. No need for cast-iron or to epoxy coat.
- Flexible design for easy replacement. Available with 4", 5", 6" and 8" Suction fittings for a perfect match.
- 6" and 8" in-line strainer tanks available for even the largest jobs.
- All models come with a heavy duty 1750 RPM TEFC motor, which due to our simple de-coupling shaft, can be easily replaced without replacing the seal.

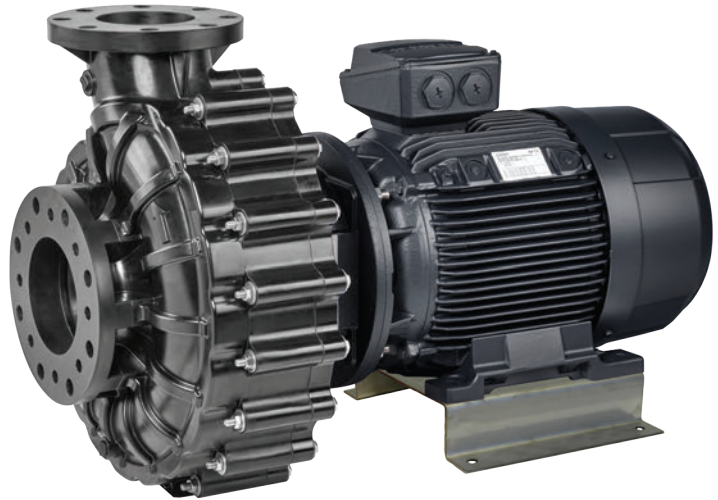

BADU Block Multi Series

Adding an Intelligent Twist to the Normblock's Design

FEATURES

- BADU Block Multi's stand conventional wisdom on its head, literally. By orienting the pump vertically, we unlock a number of extra benefits beyond those of the Normblock.
- The immensely space-saving design allows for an up to six-fold decrease in footprint.
- Independently rotating volute delivers even more flexibility, allowing for discharge articulation in eight different directions.



Normblock 150/250

Expanding Our Line

FEATURES

- Bronze impeller and volute.
No need for epoxy coating.
- Now stocking 60 HP, for even larger jobs.
- Up to 3000 GPM.



**Speck Online
Pump Selector**



Performance Curves

Normblock 150/250 (40, 50 & 60 HP)

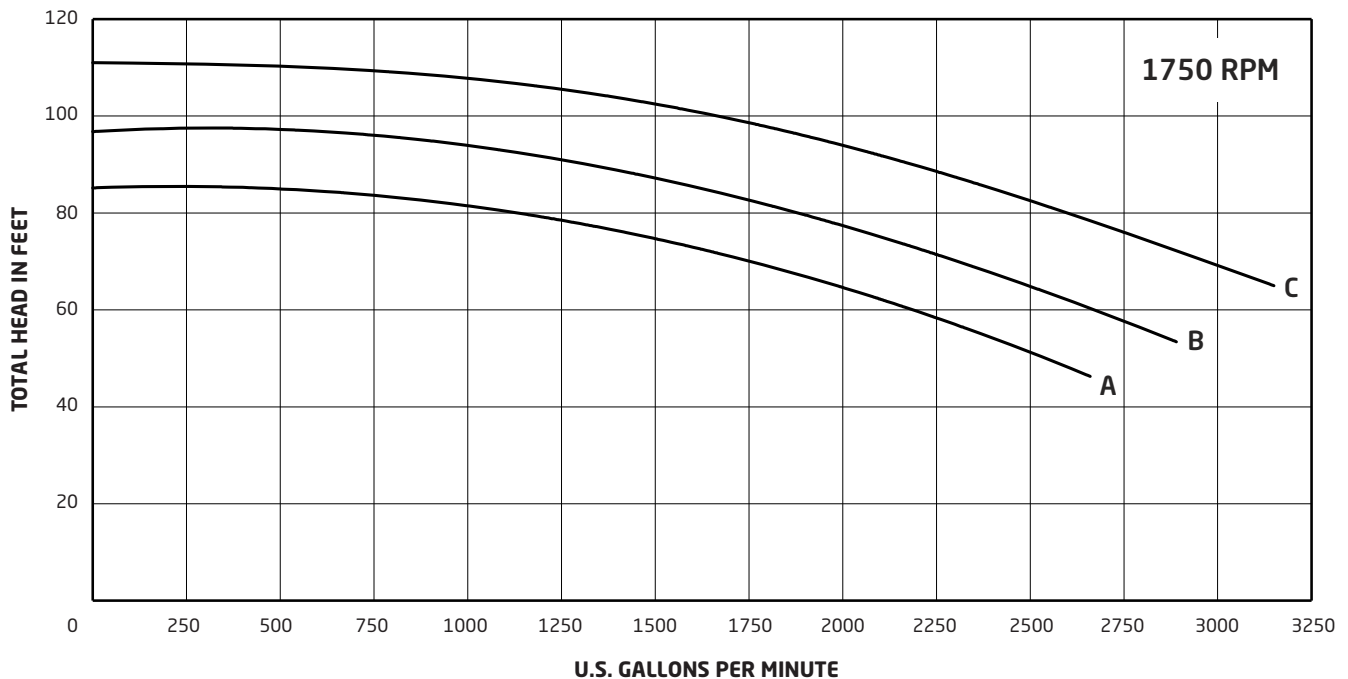

A. 150/250 (Ø 239MM) – 40 HP S.F. 1.15

B. 150/250 (Ø 258MM) – 50 HP S.F. 1.15

C. 150/250 (Ø 269MM) – 60 HP S.F. 1.15

BADU Block & Normblock Multi Series (7.5 HP, 10 HP, 15 HP, 20 HP)

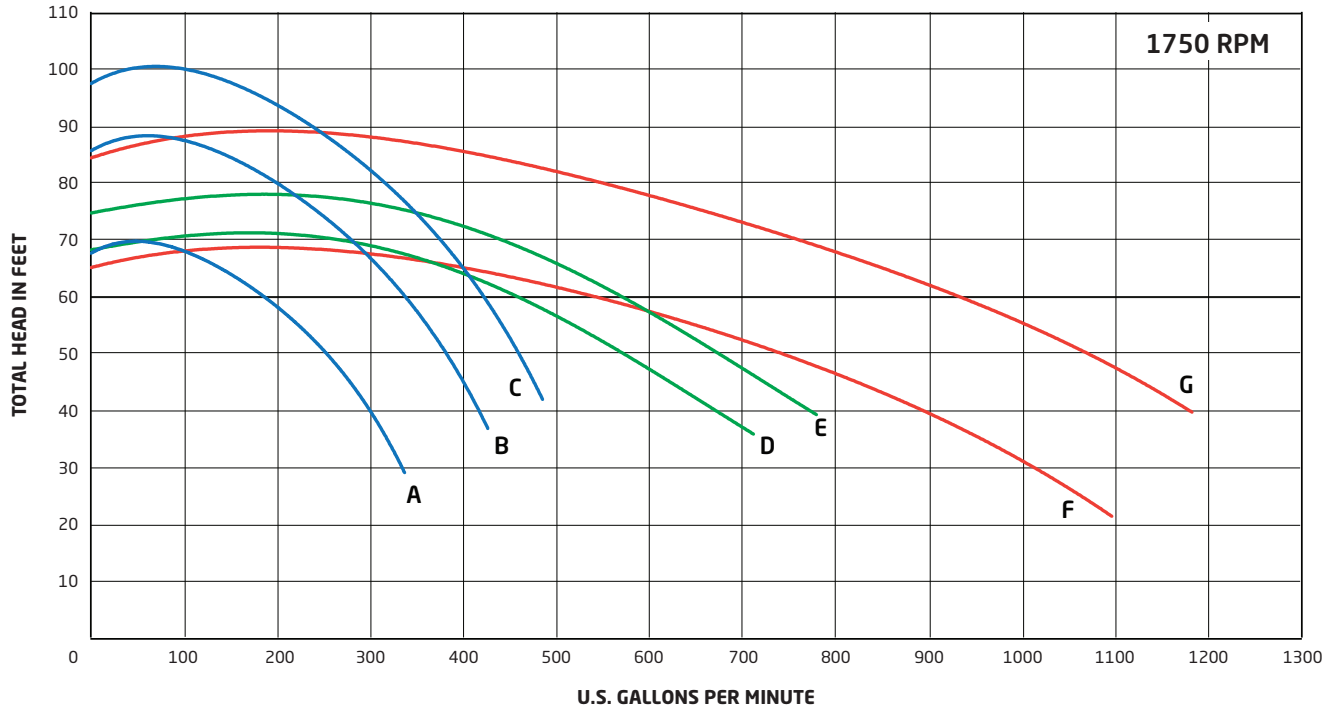

A. 65/250 (Ø 200MM) - 5.5 HP S.F. 1.25
B. 65/250 (Ø 225MM) - 7.5 HP S.F. 1.25
C. 65/250 (Ø 240MM) - 10 HP S.F. 1.25

D. 80/200 (Ø 215MM) - 10 HP S.F. 1.25
E. 80/200 (Ø 225MM) - 15 HP S.F. 1.25

F. 100/250 (Ø 220MM) - 15 HP S.F. 1.25
G. 100/250 (Ø 240MM) - 20 HP S.F. 1.25

BADU Block & Normblock Multi 125/250 Series (20 HP, 25 HP, 30 HP)

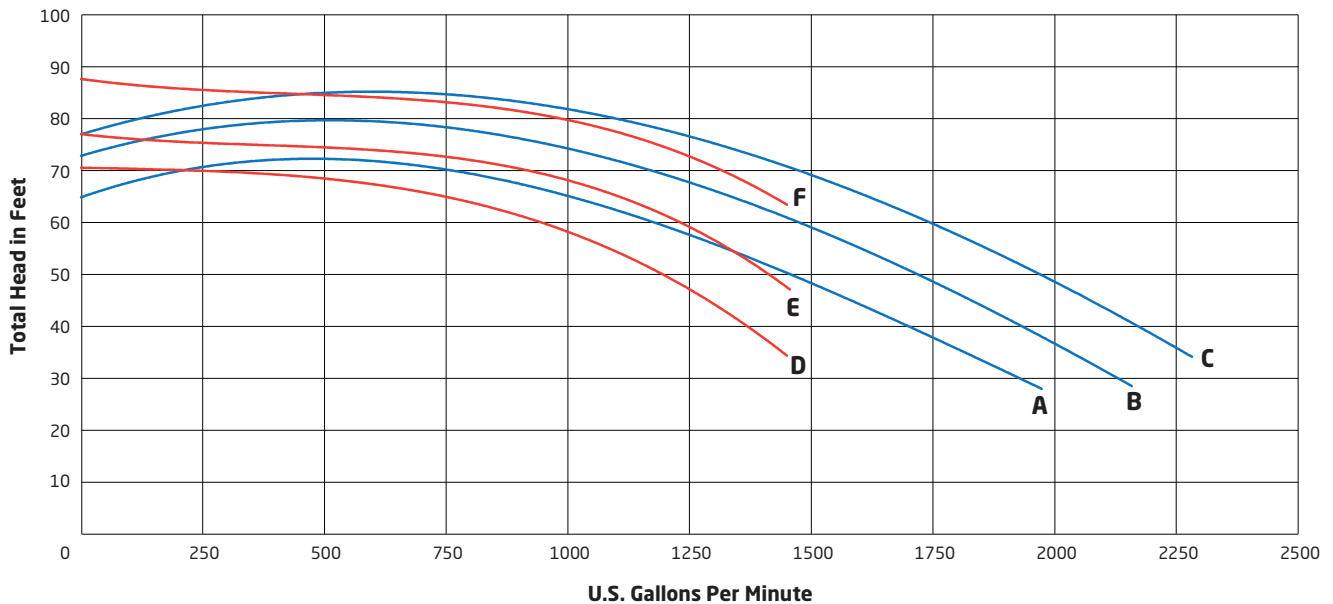

Normblock Multi 125/250
(Horizontal Pump)

A. 125/250 (Ø 235mm) - 20 HP S.F. 1.25
B. 125/250 (Ø 245mm) - 25 HP S.F. 1.15
C. 125/250 (Ø 255mm) - 30 HP S.F. 1.15

BADU Block Multi 125/250
(Vertical Pump w/ ceramic coated cast iron strainer housing - 10" suction port)

A. 125/250 (Ø 235mm) - 20 HP S.F. 1.25
B. 125/250 (Ø 245mm) - 25 HP S.F. 1.15
C. 125/250 (Ø 255mm) - 30 HP S.F. 1.15

BADU Block Multi 125/250
(Vertical Pump w/ plastic strainer housing - 8" suction port)

D. 125/250 (Ø 235mm) - 20 HP S.F. 1.25
E. 125/250 (Ø 245mm) - 25 HP S.F. 1.15
F. 125/250 (Ø 255mm) - 30 HP S.F. 1.15

Strainer Tanks

6"x6" and 8"x8"

The largest all-plastic strainer tank on the market. Tanks are rated up to 2200 GPM. Both models are compatible with the Normblock pump series.

FEATURES

- This strainer is made from high quality polypropylene.
- Clear polycarbonate strainer lid enables easy viewing of the strainer basket.
- Available with optional ANSI flange kits.
- Flow rates:
 - 6" model allows flow rates up to 700 GPM.
 - 8" model allows flow rates up to 2200 GPM.



Strainer Tank (8"x8")

Strainer 6"x 6"

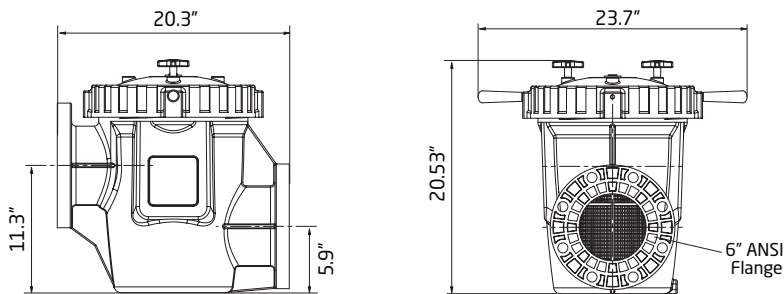

Normblock Multi (100/250) with 6" In-Line Strainer Tank

Strainer 8"x 8"

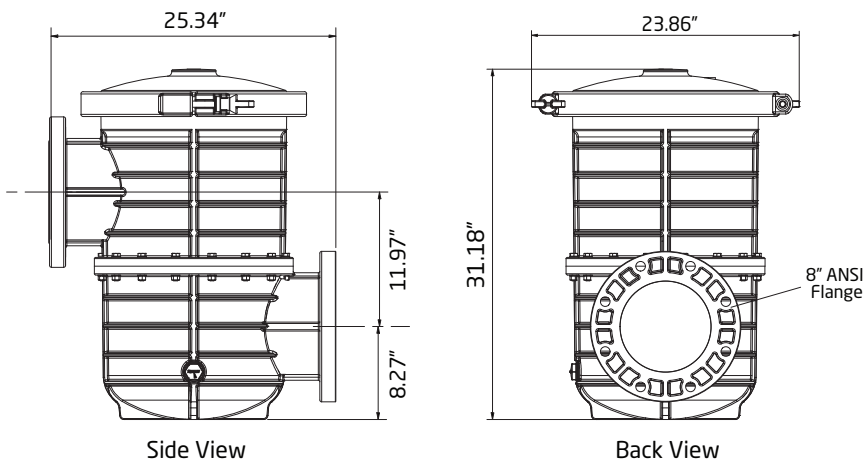

Normblock Multi (150/250) with 8" In-Line Strainer Tank

Performance Curves

Strainer Tank 6"x6"

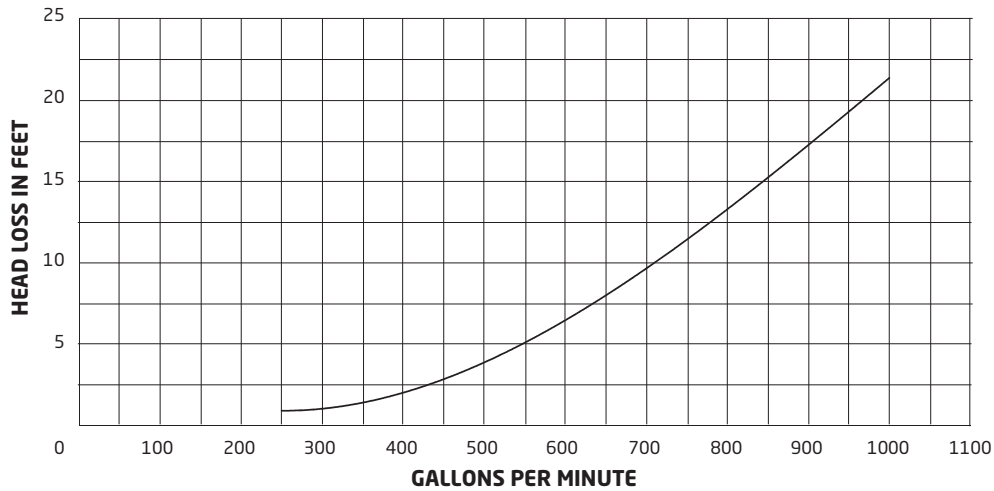

Strainer Tank 8"x8"

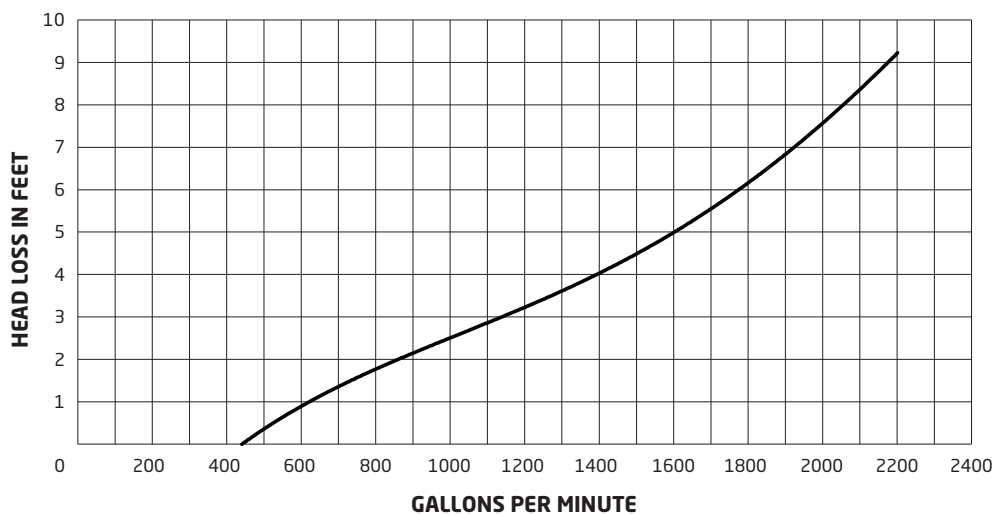

Part Numbers

Strainer Tanks

Order #	Description
7319B05008	6"x6" Strainer Tank & Hardware for Normblock Multi (6" Suction / 6" Pump Connection)
7201800001	8"x8" Strainer Tank CPL with Hardware
7201800100	8"x8" Strainer Tank, Flange Adaptor & Hardware for the Normblock Multi 100/250
7201800125	8"x8" Strainer Tank, Flange Adaptor & Hardware for the Normblock Multi 1.25/250

Flange Kits

Order #	Description
7300000040A	ANSI 3" Flange Kit - Includes two-piece ANSI class 150 flange, gasket and stainless steel bolts
7300000034A	ANSI 4" Flange Kit - Includes two-piece ANSI class 150 flange, gasket and stainless steel bolts
7300000050A	ANSI 5" Flange Kit - Includes two-piece ANSI class 150 flange, gasket and stainless steel bolts and 5" to 6" coupling
7300000036A	ANSI 6" Flange Kit - Includes two-piece ANSI class 150 flange, gasket and stainless steel bolts
7300000038A	ANSI 8" Flange Kit - Includes two-piece ANSI class 150 flange, gasket and stainless steel bolts

Part Numbers

Normblock Multi Models - (Pump Only Without Strainer) **Three Phase; 60 Hz; TEFC motor**

Order #	Model	HP	S.F.	Volts	Full Load Amps	Standard Flange Sizes* Suction/Discharge
NB715-1005F-000	65/250	5.5	1.25	208-230/460 V	13.9 - 13.2 / 6.6	ANSI 4" / 3"
NB715-1007F-000	65/250	7.5	1.25	208-230/460 V	20.1 - 18.1 / 9.07	ANSI 4" / 3"
NB715-1010F-000	65/250	10	1.25	208-230/460 V	27.4 - 24.8 / 12.4	ANSI 4" / 3"
NB715-1010F-080	80/200	10	1.25	208-230/460 V	27.4 - 24.8 / 12.4	ANSI 6" / 4"
NB715-1015F-080	80/200	15	1.25	208-230/460 V	40.3 - 36.4 / 18.2	ANSI 6" / 4"
NB715-1015F-000	100/250	15	1.25	208-230/460 V	40.3 - 36.4 / 18.2	ANSI 6" / 4"
NB715-1020F-000	100/250	20	1.25	208-230/460 V	55.3 - 50.0 / 25.0	ANSI 6" / 4"
NB715-1020F-016	125/250	20	1.25	208-230/460 V	55.3 - 50.0 / 25.0	ANSI 6" / 5"
NB715-1025F-000	125/250	25	1.15	208-230/460 V	67.7 - 61.2 / 30.6	ANSI 6" / 5"
NB715-1030F-000	125/250	30	1.15	208-230/460 V	79.6 - 72.0 / 36.0	ANSI 6" / 5"

NOTE: Normblock Multi pumps are also available with 575 V motors. Please call customer service at (800) 223-8538 for a quote.

BADU Block Multi Series - (Vertical Pump with Polyurethane Strainer Tank & Stainless Steel Basket) **Three Phase; 60 Hz; TEFC motor**

Order #	Model	HP	S.F.	Volts	Full Load Amps	Standard Flange Sizes* Suction/Discharge
Models w/ Polyurethane Strainer Tank						
BB705-1005F-000	65/250	5.5	1.25	208-230/460 V	13.9 - 13.2 / 6.6	ANSI 6" / 3"
BB705-1007F-000	65/250	7.5	1.25	208-230/460 V	20.1 - 18.1 / 9.07	ANSI 6" / 3"
BB705-1010F-000	65/250	10	1.25	208-230/460 V	27.4 - 24.8 / 12.4	ANSI 6" / 3"
BB705-1010F-080	80/200	10	1.25	208-230/460 V	27.4 - 24.8 / 12.4	ANSI 8" / 4"
BB705-1015F-080	80/200	15	1.25	208-230/460 V	40.3 - 36.4 / 18.2	ANSI 8" / 4"
BB705-1015F-000	100/250	15	1.25	208-230/460 V	40.3 - 36.4 / 18.2	ANSI 8" / 4"
BB705-1020F-000	100/250	20	1.25	208-230/460 V	55.3 - 50.0 / 25.0	ANSI 8" / 4"
BB705-1020F-016	125/250	20	1.25	208-230/460 V	55.3 - 50.0 / 25.0	ANSI 8" / 5"
BB705-1025F-000	125/250	25	1.15	208-230/460 V	67.7 - 61.2 / 30.6	ANSI 8" / 5"
BB705-1030F-000	125/250	30	1.15	208-230/460 V	79.6 - 72.0 / 36.0	ANSI 8" / 5"

Models w/ Ceramic Coated Cast Iron Strainer Tank

BB70I-1020F-016	125/250	20	1.25	208-230/460 V	55.3 - 50.0 / 25.0	DN250-10" / ANSI 5"
BB70I-1025F-000	125/250	25	1.15	208-230/460 V	67.7 - 61.2 / 30.6	DN250-10" / ANSI 5"
BB70I-1030F-000	125/250	30	1.15	208-230/460 V	79.6 - 72.0 / 36.0	DN250-10" / ANSI 5"

NOTE: BADU Block Multi pumps are also available with a 575 V motor. Please call customer service at (800) 223-8538 for a quote.

BADU Block 150/250 Series - (Vertical Pump with Integrated Strainer Tank)

Order #	Model	HP	S.F.	Motor Data (Phase; Voltage; Amps)	Standard Flange Sizes* Suction/Discharge
BB705-1040F-NEC	150/250	40	1.15	3 PH; 60 Hz; 208-230/460 V; TEFC	DN250-10" / DN150-6"
BB705-1050F-NEC	150/250	50	1.15	3 PH; 60 Hz; 208-230/460 V; TEFC	DN250-10" / DN150-6"
BB705-1060F-NEC	150/250	60	1.15	3 PH; 60 Hz; 208-230/460 V; TEFC	DN250-10" / DN150-6"

Normblock 150/250 Series - (Horizontal Pump without Strainer)

Order #	Model	HP	S.F.	Motor Data (Phase; Voltage; Amps)	Standard Flange Sizes* Suction/Discharge
NB715-1040F-NEC	150/250	40	1.15	3 PH; 60 Hz; 208-230/460 V; TEFC	DN200-8" / DN150-6"
NB715-1050F-NEC	150/250	50	1.15	3 PH; 60 Hz; 208-230/460 V; TEFC	DN200-8" / DN150-6"
NB715-1060F-NEC	150/250	60	1.15	3 PH; 60 Hz; 208-230/460 V; TEFC	DN200-8" / DN150-6"

*NOTE: Flange Kits are sold separately.

8125 Bayberry Road
Jacksonville, FL 32256 USA

Toll Free 800.223.8538
Phone 904.739.2626

info.usa@speck-pumps.com
usa.speck-pumps.com



SPECK X
pumps