

Model 433

High Performance, High Head Pump



The Model 433 is a high head, medium flow workhorse, equipped with three phase motor.

Features

- This high performance, high head pump comes complete with our unique mechanical shaft seal that allows the pump, if mistreated, to run dry for up to one hour.
- The pump can be used for pool water with a salt concentration of up to 5000 ppm.
- Non-corrosive, chemical/UV resistant, and can withstand temperatures of up to 175°F.
- Suction and discharge are reinforced with aluminum rings.
- The Model 433 is available with the following motor options:
 - Single Speed, Three Phase (0.5 to 3.0 HP)
 - Variable Speed, Single Phase (2.25 & 2.7 THP)
- Lock ring that incorporates handles. These handles provide the user with a convenient way to easily remove the lid.
- Flooded suction models available.
- Motor is easy to remove without disturbing the plumbing. Reusable o-rings throughout.
- Every pump is performance tested before leaving the Speck factory.

Features Specific to the Variable Speed Models

- Variable Speed motor with built-in easy to use controller LCD screen.
- RPM levels can be set to range from 600 to 3450.
- Programmable high efficiency TEFC maintenance-free permanent magnet brushless 56 frame motor with Class F insulation.
- Programmable auxiliary load feature.

Dimensional Drawing

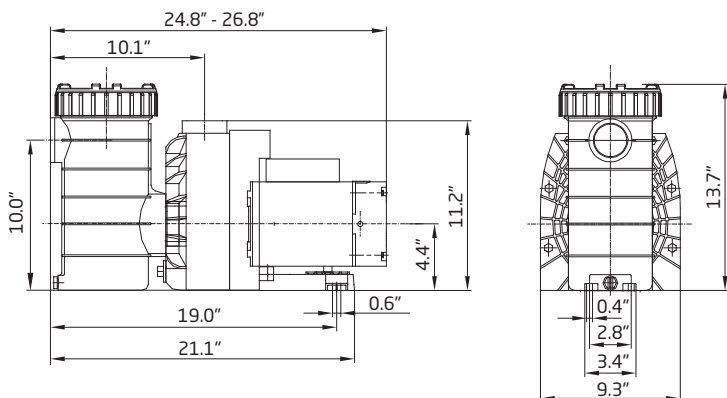

Model 433-V

Trademarks and Certifications



Performance Curves

