

# Cartridge Filter

Cartridge Filters - 90, 120, 150 & 180 sq. ft.

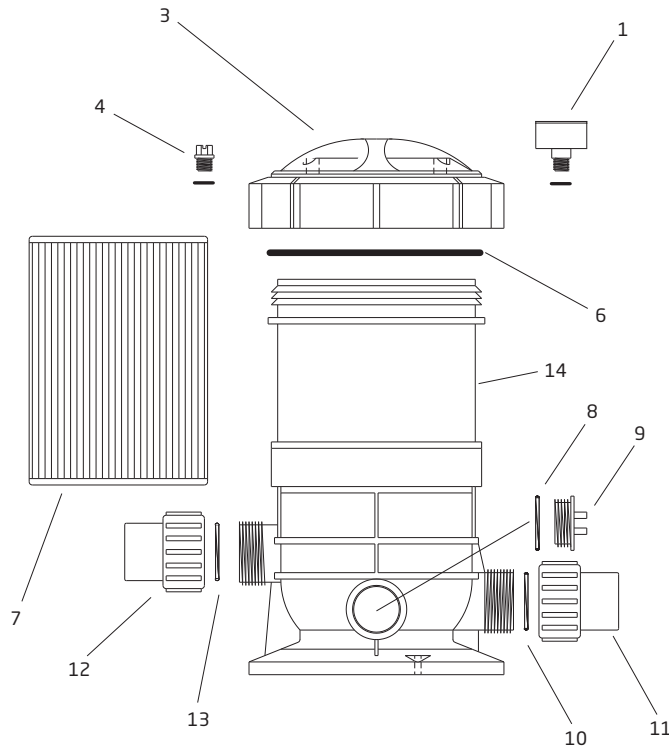

Order#	Drawing #	Description	List Price (\$)	Order#	Drawing #	Description	List Price (\$)
7200039349	1	Pressure Gauge	15.20	7300001805	7	Cartridge - Replacement (for 180 sq. ft.)	323.60
7200055000	3 & 4	Lid Assembly - Complete	106.60	7300055006	8	O-ring - Drain Plug	1.30
7200009601	4	Screw - Air Bleed w/ Gasket	4.60	7300055005	9	Drain Plug	2.80
7200055003	6	O-ring - Lid	11.10	7200055010	10-13	Union End (1.5") Slip w/ Nut & O-ring (x2)	9.50
7200080853	Not Shown	Locking Ring Latch - Lid (for 60/90/120/150/180)	8.10	7200000030	14	Filter Body (for 30 sq. ft.)	318.30
7300000305	7	Cartridge - Replacement (for 30 sq. ft.)	119.80	7200000060	14	Filter Body (for 60 sq. ft.)	382.90
7300000605	7	Cartridge - Replacement (for 60 sq. ft.)	111.00	7200000090	14	Filter Body (for 90 sq. ft.)	440.20
7300000905	7	Cartridge - Replacement (for 90 sq. ft.)	149.40	7200000120	14	Filter Body (for 120 sq. ft.)	505.70
7300001205	7	Cartridge - Replacement (for 120 sq. ft.)	206.00	7200000150	14	Filter Body (for 150 sq. ft.)	566.60
7300001505	7	Cartridge - Replacement (for 150 sq. ft.)	259.00	7200000180	14	Filter Body (for 180 sq. ft.)	641.00